

**CIPET : CENTRE FOR SKILLING AND TECHNICAL SUPPORT (CSTS), GWALIOR**

# **CIPET-CSTS GWALIOR**



## **GeM-TENDER FOR**

## **SUPPLY AND INSTALLATION OF LABORATORY FURNITURE**

**GeM-TENDER NO: CIPET-CSTS/GWL/LAB-FURNITURE/2023-24/05**

**LAST DATE FOR ONLINE SUBMISSION OF GeM-TENDER BID: 29.11.2023**

**CIPET : CENTRE FOR SKILLING AND TECHNICAL SUPPORT (CSTS)**

**Department of Chemicals & Petrochemicals**

**Ministry of Chemicals & Fertilizers**

**Govt. of India**

**Textile Technology Dept. Building, Near Women Polytechnic College,  
Padav Gwalior-474007**

**E-mail: [gwalior@cipet.gov.in](mailto:gwalior@cipet.gov.in)**

**Website: [www.cipet.gov.in](http://www.cipet.gov.in)**

**Ph.No.:+91-751-2369369**



**CIPET : CENTRE FOR SKILLING AND TECHNICAL SUPPORT (CSTS)**  
**Department of Chemicals & Petrochemicals Ministry of Chemicals & Fertilizers Govt. of India**  
Textile Technology Dept. Building, Near Women Polytechnic College,  
Padav Gwalior-474007  
E-mail: [gwalior@cipet.gov.in](mailto:gwalior@cipet.gov.in); Website: [www.cipet.gov.in](http://www.cipet.gov.in)  
Ph.No.:+91-751-2369369

## **NOTICE INVITING GeM-TENDER (NIT)**

**GeM-Tender No: CIPET-CSTS/GWL/LAB-FURNITURE/2023-24/05**

**Date: 08.11.2023**

CIPET-CSTS, Gwalior invites bids through GeM-Tender **UNDER SINGLE STAGE TWO BID SYSTEM IN GeM-TENDER PORTAL** from reputed Manufacturers/authorized suppliers & distributors for “Supply and installation of Laboratory Furniture” at CIPET-CSTS, GWALIOR. Bid offers should be of two parts viz., Technical Bid & Commercial Bid.

Sr. No.	Tender No.& Date	Name of the Item	EMD	Work Completion Time	Tender Fees in Rs.	Last Date & Time of GeM-Tender Bid Online submission
1	<b>CIPET-CSTS/GWL/LA B-FURNITURE/23-24/05</b> Date:08.11.2023	Supply and Installation of Laboratory Furniture's	Rs. 1,20,000/- (One Lakh Twenty Thousand Only)	30 Days from the date of award of Work Order	As per GeM	<b>29.11.2023</b> <b>11.00 Hrs.</b>

Interested and eligible bidders may view and download detailed tender documents from [www.cipet.gov.in](http://www.cipet.gov.in) / GeM portal.

The Tender Fee/EMD can be paid through Demand Draft and EMD will be accepted in the form of Demand Draft only drawn through any Nationalized Bank favoring “CIPET” payable at Gwalior and shall be submitted at CIPET : CSTS, Gwalior as specified on or before **29.11.2023** up to 11.00 Hrs along with the tender documents.

### **SALIENT INFORMATION ABOUT THE TENDER:**

1. Mode of submission Online will start w.e.f. 08.11.2023.
2. Who can participate for this Tender: Reputed Manufacturers/authorized suppliers & distributors of Laboratory Furniture
3. Date & Time of Technical Bid Opening : **29.11.2023** at 11:30Hrs.
4. Date & Time of Financial Bid Opening: Technically qualified bidders will be intimated about the date and time of financial bid opening.
5. Bid Opening Venue : CIPET:CSTS, Gwalior, Textile technology department building, near women polytechnic college, Padav Gwalior- 474007.

6. Eligibility Criteria:-All points mentioned in Annexure- I also for Technical evaluation:

Age of the Firm	:	03 Years as on 31.03.2023
Annual Turnover	:	Average of Rs.100 Lakhs & above in last 03 financial years.
Individual Work Order	:	Minimum 03 work order and work completion forms stating the quality of work and similar work experience certificate of Rs.12 lakhs or above or One similar completed work costing not less than the amount equal to Rs.25.00 Lakhs.

7. Additional Certificates to be submitted by the bidder/parent company:

- a. ISO 9001-2015
- b. ISO14001-2015

8. The bidder or its parent company in India should have a well—established (their own) in house manufacturing unit for the steel laboratory furniture and fume hood, quality management system as per national/international standards providing the products and services on the continuous basis for the last 3years.The bidder or its parent company in India should possess valid approval for the manufacturing such items by a statutory authority.
9. Make In India Certification (on the letter Head) for minimum local content as prescribed for Class I local Supplier & Class II Local Supplier.
10. The bidder should provide client list along with name and contact details to whom they have supplied earlier.

## **INTRODUCTION**

CIPET : Central Institute of Petrochemicals Engineering & Technology was established in 1968 by Government of India with the assistance of United Nations Development Programme (UNDP) at Chennai. The main objective of setting up of the institute was to develop manpower in different disciplines of Plastics Engineering & Technology as no similar institute was in existence in the country. International Labour Organization (ILO) served as the executing agency. During the initial project period between 1968 and 1973, the institute achieved the targets envisaged and was rated as one of the most successful UNDP projects implemented worldwide. Today CIPET is a premier national institution under the aegis of the Ministry of Chemicals & Fertilizers, Govt. of India fully devoted to Skill Development, Technology Support Services, Academic and Research (STAR). CIPET operates on hub & spokes model with 28 locations - 5 High Learning Centres, 12 Other Learning Centres, 3 Specialized Centres, 2 R & D Wings, 5 Vocational Training Centre, 1 Petrochemical Data Services spread across the country catering to the needs of Polymer and allied industries. 11 more centres are in the process of establishment.

CIPET stands tall not only as a premier institute in the country but also emerged as a global institution renowned for its research & development in the niche areas of Polymer Science & Technology and high quality Education & Skill development in the field of plastics. CIPET has been accredited with ISO9001:2008QMS, ISO/IEC-17025, ISO/IEC-17020 certification on Design, Development and Conduct of specialized training courses in Plastics Engineering & Technology and rendering technical / consultancy services in design, tooling, plastics processing & testing for the benefit of plastics & allied industry. Besides, STAR activities, CIPET also plays pivotal role in generating employment opportunities especially for unemployed and underemployed youth, promoting entrepreneurs through various skill development training programs.

Headquartered in Chennai, CIPET has centres at Ahmedabad, Amritsar, Aurangabad, Baddi, Balasore, Bhopal, Bhubaneswar, Chennai, Gurgaon, Guwahati, Gwalior, Hyderabad, Hajipur, Haldia, Imphal, Jaipur, Kochi, Korba, Lucknow, Madurai, Murthal, Mysore, Raipur, Valsad and Vijayawada. All the state-of-the-art centers are equipped with excellent infrastructure facilities in the areas of Design, CAD/CAM/CAE, Tooling & Mould Manufacturing, Plastics processing, Testing and Quality Assurance with plan fund support from Government of India. The infrastructure facilities in terms of machinery, equipments and technology are continuously upgraded and modernized in tune with the needs of plastics & allied industries.

CIPET renders Technology Support Service in the areas of design, tooling, plastics processing and testing and quality assurance in India and abroad. CIPET has been in the forefront of strengthening the technological capabilities and has been constantly building capacities and leveraging its expertise, caliber and skill sets to meet the emerging and evolving needs of the industries.

CIPET Centre in the state of Madhya Pradesh was established at Bhopal in the year 1987-88 and at Gwalior in the year 2016-17. It is situated in "Dang Maharajpura Gwalior" and is spread in an area of 10 acres. Work of building construction is under progress.

## SPECIFICATION/ SCOPE OF WORK

<b>Sl. No.</b>	<b>Item</b>	<b>Description</b>
<b>AS PER ANNEXURE - I</b>		

## **TERMS AND CONDITIONS**

1. Any Tender received by the CIPET GWALIOR after the dead line will be rejected.
2. The bids shall remain valid for period of 180 days from the date of opening of financial bid of tender.
3. The bidder has to supply the Lab Furniture within 30 days from the date of award of work order issued by CIPET GWALIOR.
4. In case of work not completed satisfactory or in case of delay, CIPET-CSTS GWALIOR reserves the right to forfeit the EMD and charge penalty on supplier as decided by CIPET-CSTS GWALIOR's management. The decision of CIPET GWALIOR management shall be final in all matters and binding on the bidder.
5. The bidders shall indemnify CIPET GWALIOR against any payment and for non-observance of the Contract Labour (Regulation & Abolition) Act'1970.
6. The payment will be paid within 30 days after successful completion of work. The bidder has to get the completion report duly authorized by the Head of the Department for processing of the bill.
7. TDS (Tax Deducted at Source) and any other applicable tax shall be deducted as per prevailing rules and regulations of the Government of India, if applicable.
8. Financial Bid should be submitted in the prescribed format Annexure-IV as given in the tender document.
9. The competent authority at its own discretion depend on the nature of work can increase the quantum of work as per requirement for the agreed value to the L1 bidder. The rates quoted by the bidder should be valid for period of 180 days without any alteration and no escalation on any account whatsoever shall be paid for this work by CIPET-CSTS GWALIOR.
10. In case of any dispute or differences arising between the CIPET-CSTS GWALIOR and bidder relating to any matter arising out or connected with this tender, such dispute or differences shall be settled within the Jurisdiction of GWALIOR Court and the language of communication should be in English only.
11. CIPET-CSTS GWALIOR reserves the absolute right to accept /reject any or all bids at any stage of the tender process without assigning any reason whatsoever.
- 12. Earnest Money Deposit:**  
Earnest money deposit shall be **1,20,000/- (Rupees One Lakh Twenty Thousand only)** through Demand Draft drawn in any nationalized bank in favour of **CIPET-CSTS,GWALIOR**.
13. The EMD of the unsuccessful Bidders will be return back after finalization of GeM-Tender. EMD & Tender Fees Will be exempted for NSIC/MSME Firms.
14. Exemption like Tender Fees/ EMD/ Annual Turn Over may be given to the bidder based on submission of valid registration certificate of Start-ups/ order issued by Government.
15. The cost of the tender documents applicable **As per GeM terms & condition** is to be paid in the form of **Demand Draft drawn in any nationalized bank in favour of CIPET** payable at **GWALIOR** which is non-refundable.
16. **Taxes :** All taxes, duties, packing & forwarding, installation and any other charges other than GST shall be deemed to have been included in the quoted rate.
17. **Performance Security :03%** of the Work Order value shall be submitted by the party towards performance security within 7 days of receipt of Work Order in the form of Demand Draft. 50% towards Performance Security will be refunded after successful supply & installation and the remaining 50% after warranty period is over.
18. **Warranty:** All the items should be covered under warranty from the date of installation.
19. The Bidders are required to have a survey including the site visit before furnishing the GeM-Tender.
20. The Furniture to be fixed/provided as per proposed/ tentative drawings attached with this tender.

**TECHNICAL BID****GeM-TENDER No: CIPET-CSTS/GWL/LAB-FURNITURE/2023-24/05****DESCRIPTION :SUPPLY AND INSTALLATION OF LABORATORY FURNITURE**

<b>S. No.</b>	<b>Particulars</b>	<b>Please Fill/Tick(✓)</b>
1	Name of the Supplier/Manufacturer	
2	Postal address	
3	Telephone No. with STD code	
4	Fax with STD code	
5	Name of Contact person	
6	Mobile No.	
7	E-Mail ID	
	<b>Following Documents to be submitted Online &amp; hardcopy submit duly sealed and signed.</b>	
a	The firm should have valid registration certificate in support of establishment of The firm	<b>Enclosed /Not Enclosed</b>
b	PAN(Permanent Account Number)Registration	<b>Enclosed /Not Enclosed</b>
c	Certificates of GST Registration	<b>Enclosed /Not Enclosed</b>
d	The firm Should be Manufacturer, Authorized Dealer/Distributor/Supplier	<b>Enclosed /Not Enclosed</b>
e	Minimum 03 work order and work completion forms stating the quality of work and similar work experience certificate of Rs.12 lakhs or above or One similar completed work costing not less than the amount equal to Rs.25.00 Lakhs.	<b>Enclosed /Not Enclosed</b>
f	The firm should have Average Annual Turnover valuing more than Rs.100.00Lakhs and above during the last 03 financial years (2020-21, 2021-22 & 2022-23)in prescribed format(Annexure-A) and with CA Certificate	<b>Enclosed /Not Enclosed</b>
g	The firm should enclose Audited Final Account (Balance Sheet, Profit & Loss A/c & Trading A/c) during the last Three Financial Years (2020-21, 2021-22 & 2022-23)	<b>Enclosed /Not Enclosed</b>
h	The firm should enclose Income Tax Return during the last Three Assessment Years (2020-21, 2021-22 & 2022-23)	<b>Enclosed /Not Enclosed</b>
i	Performa For Performance Statement	<b>Enclosed /Not Enclosed</b>
j	Demand Draft No. & Date for Tender Fees	<b>Enclosed /Not Enclosed</b>
k	Demand Draft No. &Date for EMD/ exemption certificate of EMD by NSIC / MSME Firms	<b>Enclosed /Not Enclosed</b>
l	List of Customers	<b>Enclosed /Not Enclosed</b>

**Date:****Seal &Sign.of bidder****Place:**

**(In Letter Head)**

**CERTIFICATION OF VERIFICATION BY THE CHARTERED ACCOUNTANT**

This is to certify that the total annual turnover-over all from business furnished by M/s.  
..... for the last three years i.e. 2020-21, 2021-  
22 & 2022-23 is as detailed below and as furnished in the enclosed statement of accounts, is  
verified by us and found correct.

<b>Sr.No.</b>	<b>Financial Year</b>	<b>Annual Turnover (in Lakhs)</b>
1.	2020–2021	
2.	2021-2022	
3.	2022-2023	

CHARTERED ACCOUNTANT  
SIGNATURE WITH SEAL

MY MEMBER SHIP NO. \_\_\_\_\_



# **General Instruction For GeM-tendering**

## **GeM-tendering Process:**

While uploading/submitting the documents, it should be ensured that the file name should be the name of the document itself. Interested and eligible bidders may view and download detailed GeM-tender documents from GeM portal/[www.cipet.gov.in](http://www.cipet.gov.in) , all Bids of tender must be submitted through the GeM portal.

EMD will be accepted in the form of Demand Draft drawn on any Nationalized Bank favoring “CIPET” payable at Gwalior and shall be submitted at CIPET:CSTS, GWALIOR as specified on or before **29.11.2023 up to 11.00 Hrs.** in separate sealed cover envelop failing which bids will be summarily rejected. However, a soft copy of the tender Fee and EMD instruments shall also be uploaded/mention along with the Technical Bid to be submitted through GeM.

Salient information about the GeM-tender:

1. Mode of submission: ONLINE Bid sand all technical and financial bid documents should be submitted as per GeM rules.
2. Availability of GeM-tender Documents: All Bid formats (Technical & Financial) are available ONLINE at GeM Portal & [www.cipet.gov.in](http://www.cipet.gov.in). The registered vendors can download the Bids from these GeM portal.
3. Who can participate for these tender: The registered vendors of GeM.
4. Bidders are hereby advised that all the documents to be submitted online are kept scanned and converted to PDF format in a separate folder on their computers before starting online submission. The schedule of rate (Excel Format) may be downloaded/tender to be submitted as per Gem procedure.
5. All pages of GeM-tender documents with Addenda/Corrigendum (if any) must be signed with proper official stamp and date by the Bidders or authorized power of attorney holders at the lower right hand corner.
6. Bidders are advised to **visit GeM portal regularly for any Agenda/Corrigendum** (if any) with regard to the GeM-tender for which no separate paper advertisement will not be published.
7. **Last date of online submission of GeM-tender bid:** 29.11.2023 at 11.00Hrs.
8. **EMD and GeM-tender Fee** must be in approved mode and Duly Signed & Sealed in separate cover along with filled and shall be submitted in physical form (hardcopy) in person/ by speed post at CIPET Gwalior.
9. **Date &Time of Technical Bid Opening:** 29.11.2023 at 11.30Hrs.
10. **Date &Time of Financial Bid Opening:** Technically qualified bidders will be intimated through e-mail about the date & time after Technical bid evaluation.

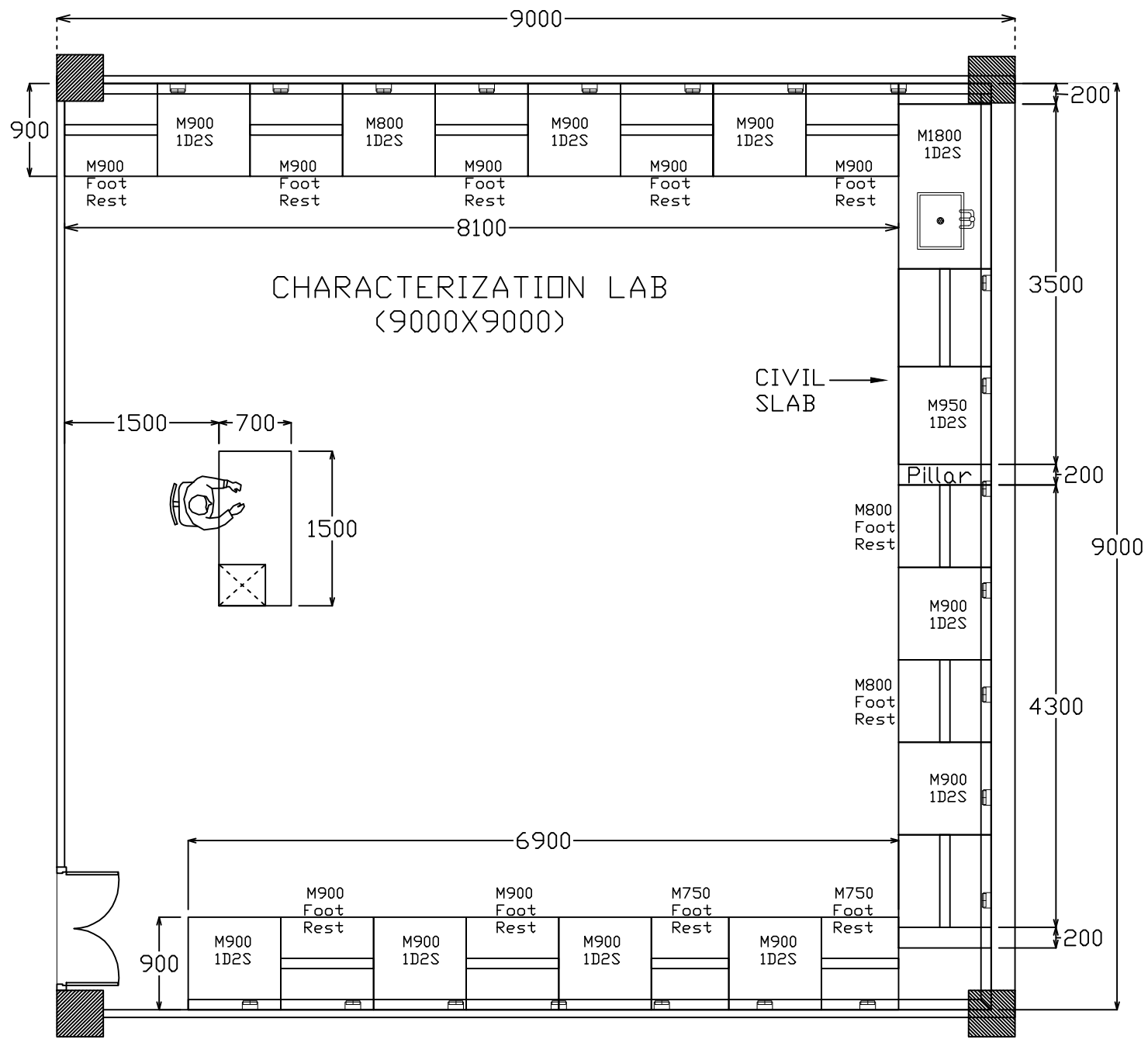

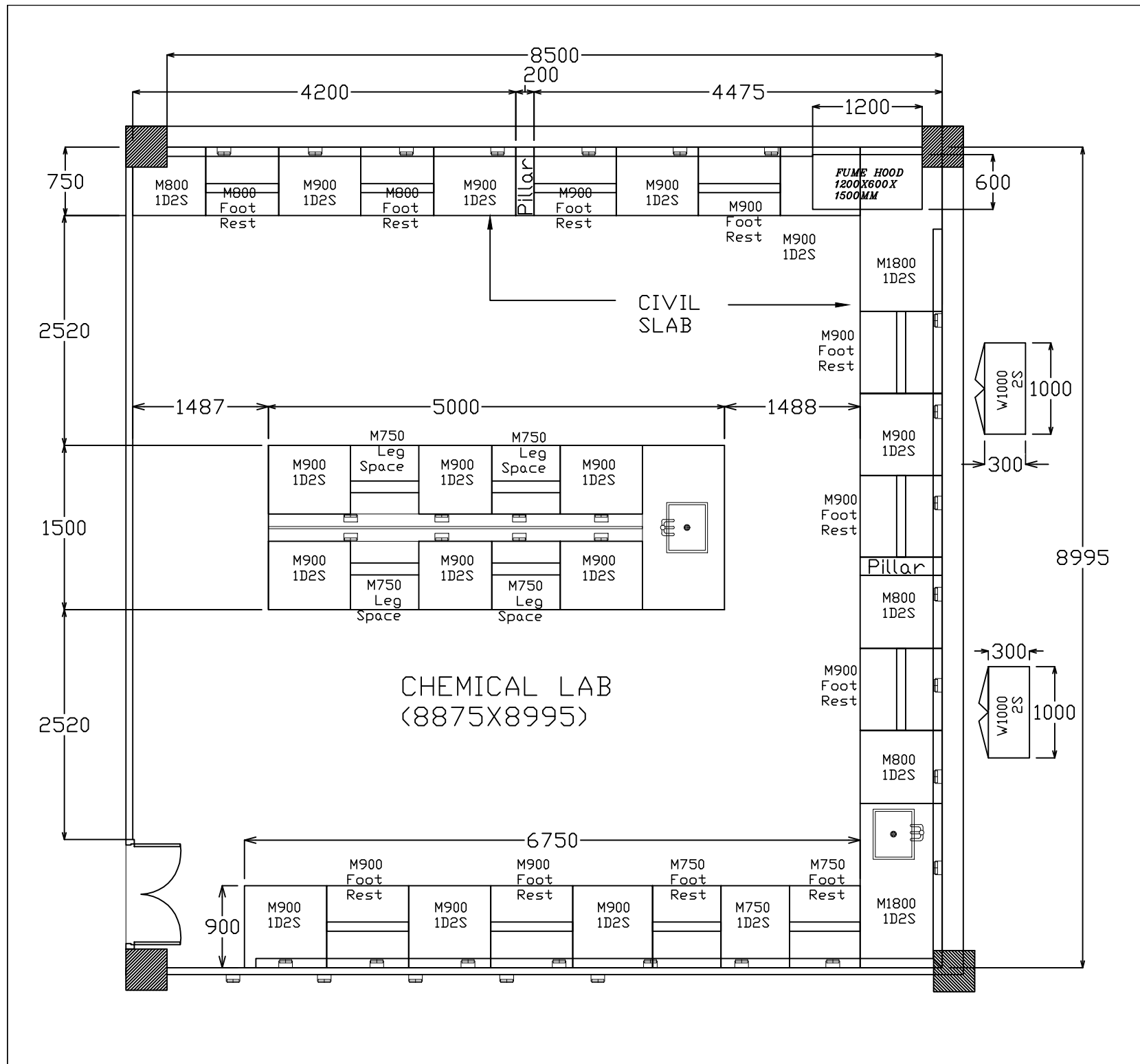

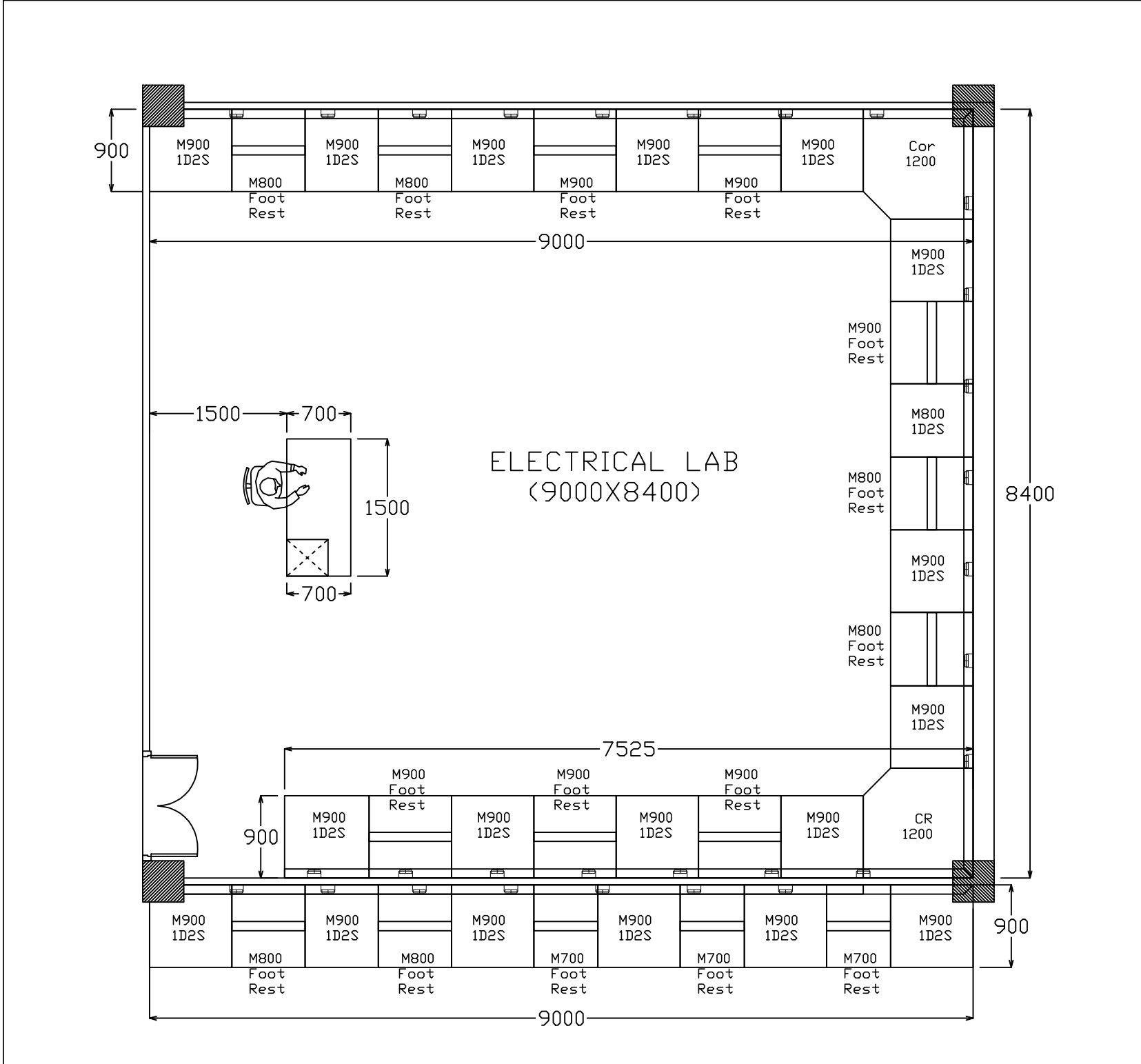

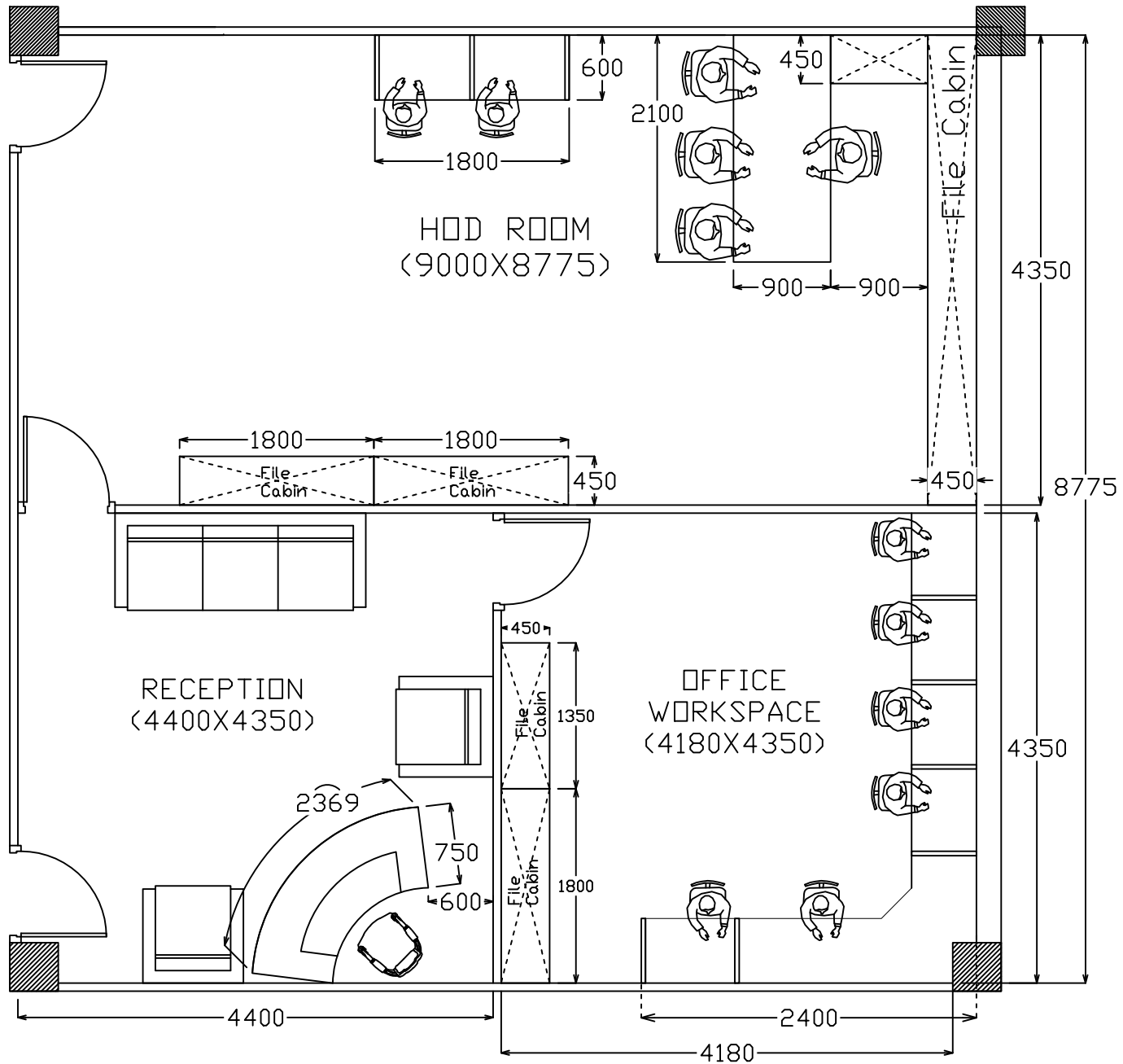

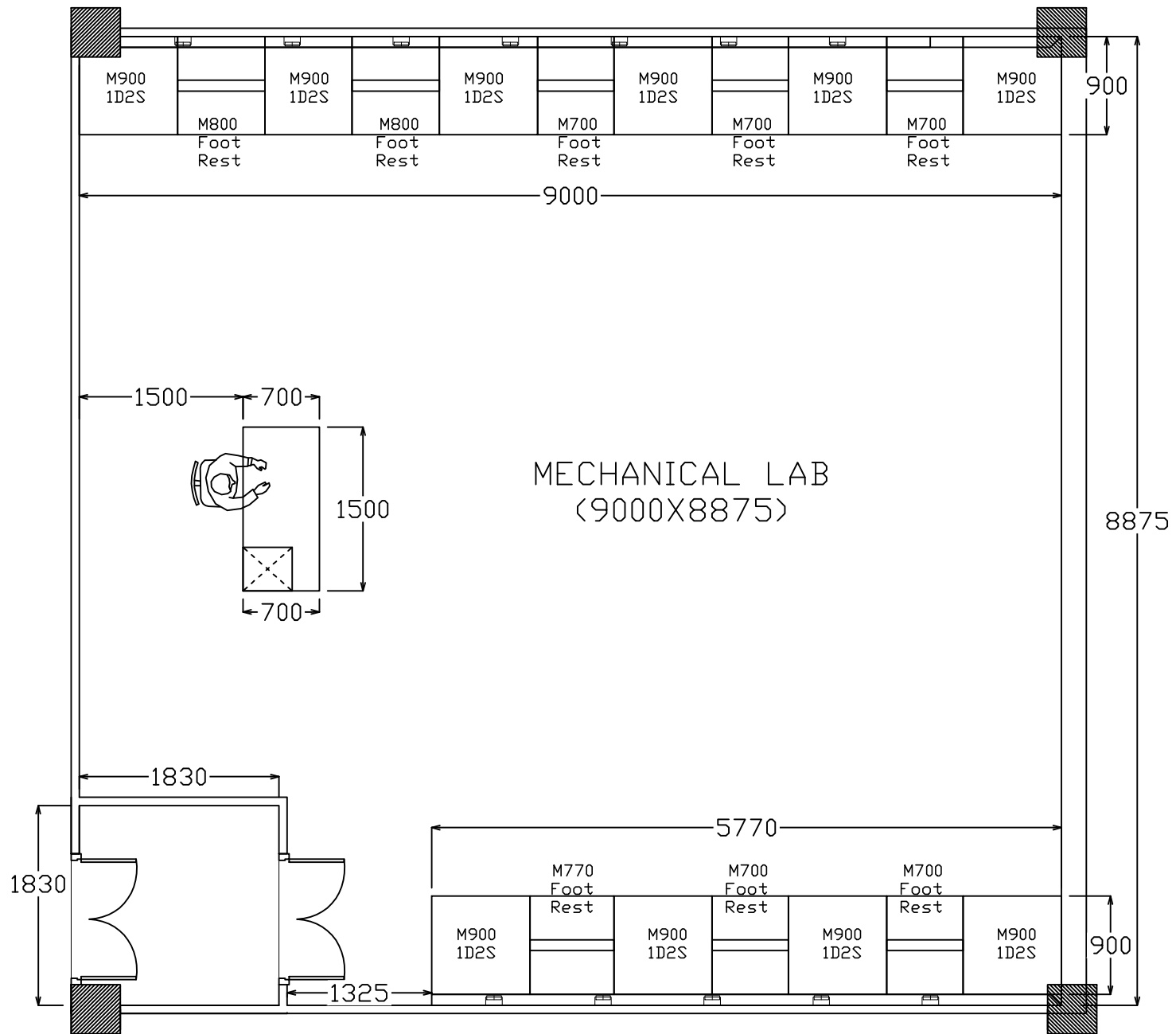

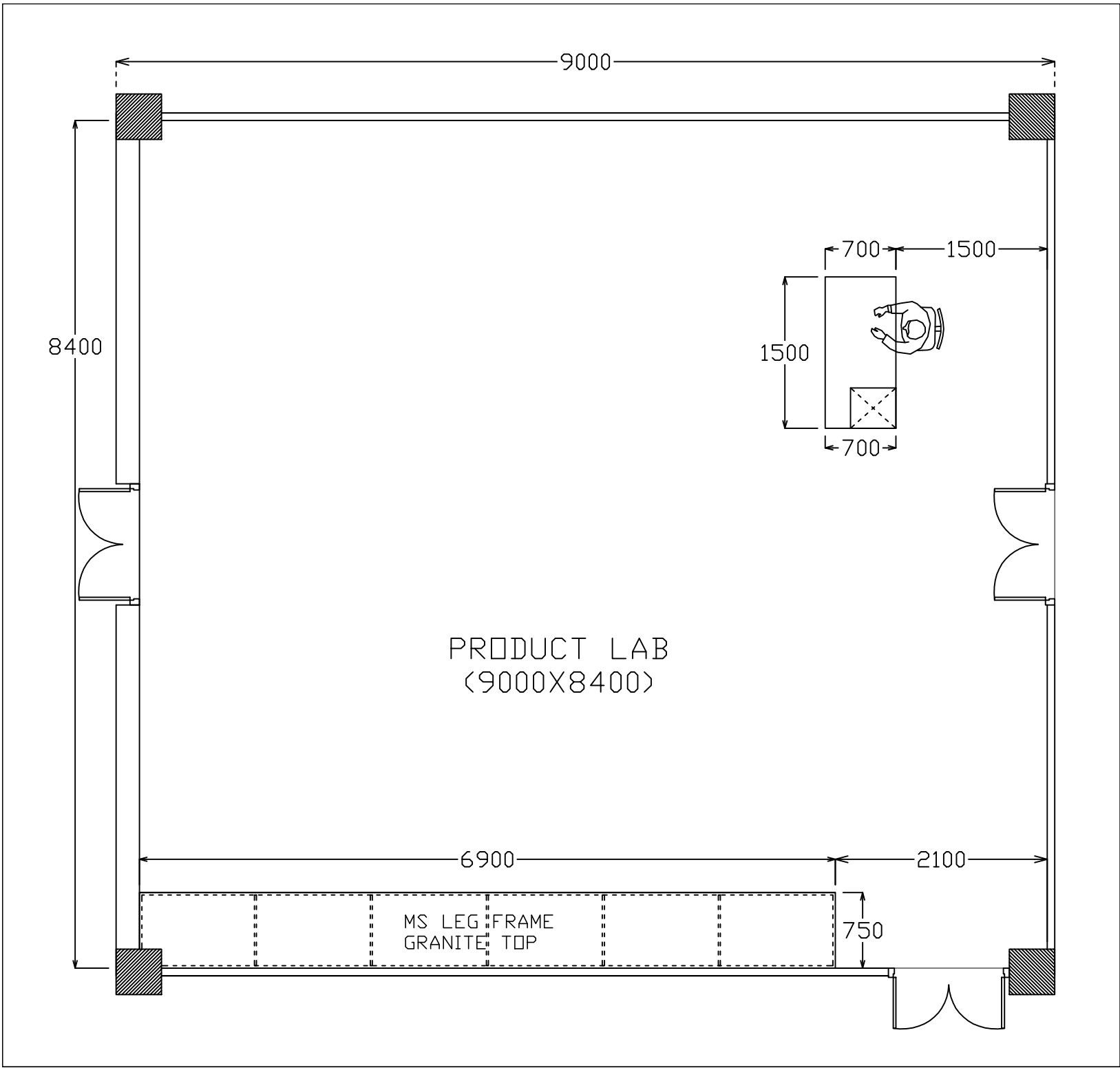

9000

8400

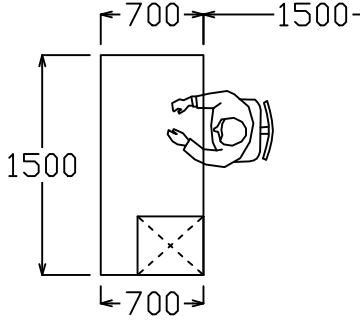

PRODUCT LAB  
(9000X8400)

6900

2100

MS LEG FRAME  
GRANITE TOP

750

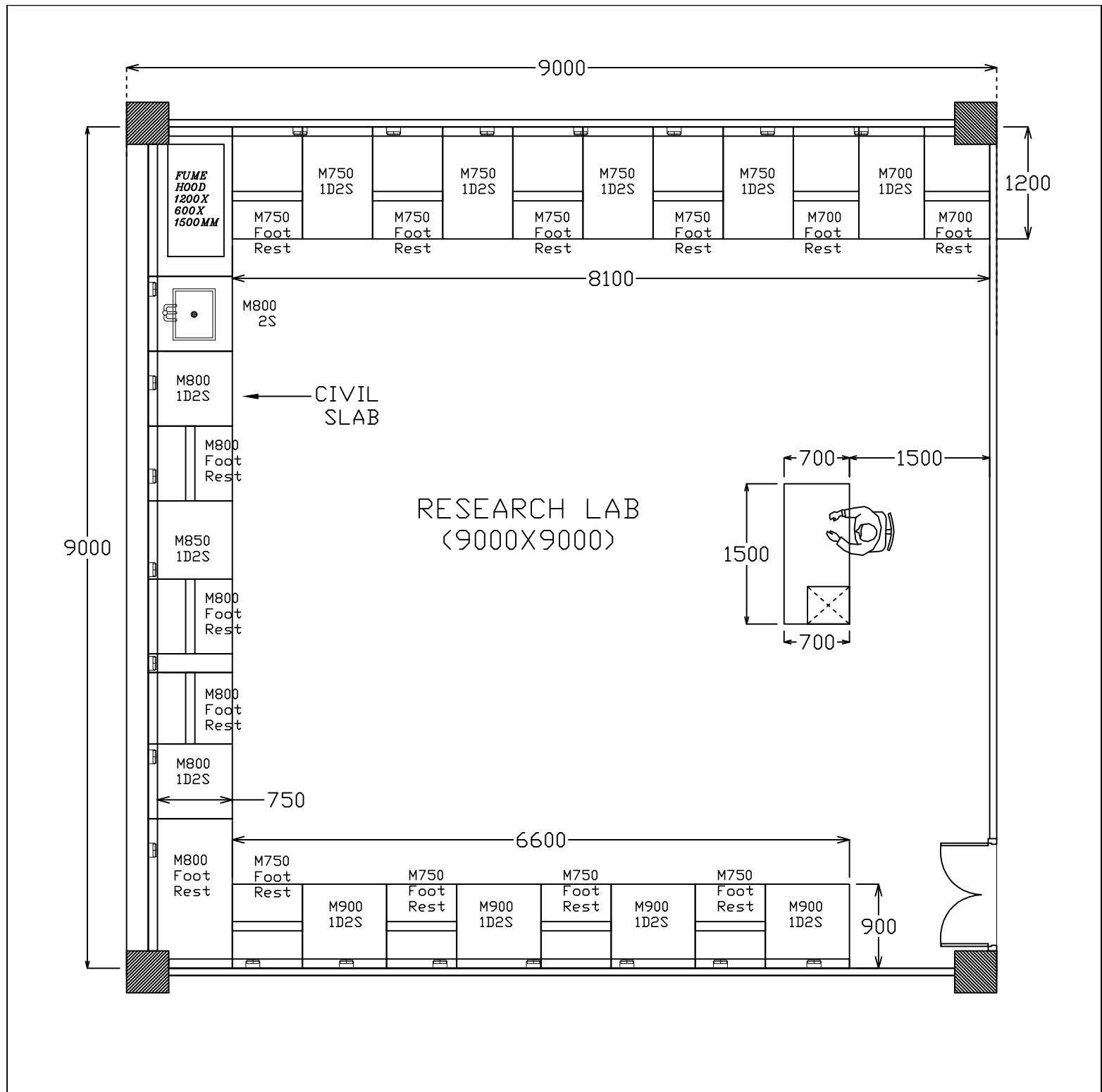



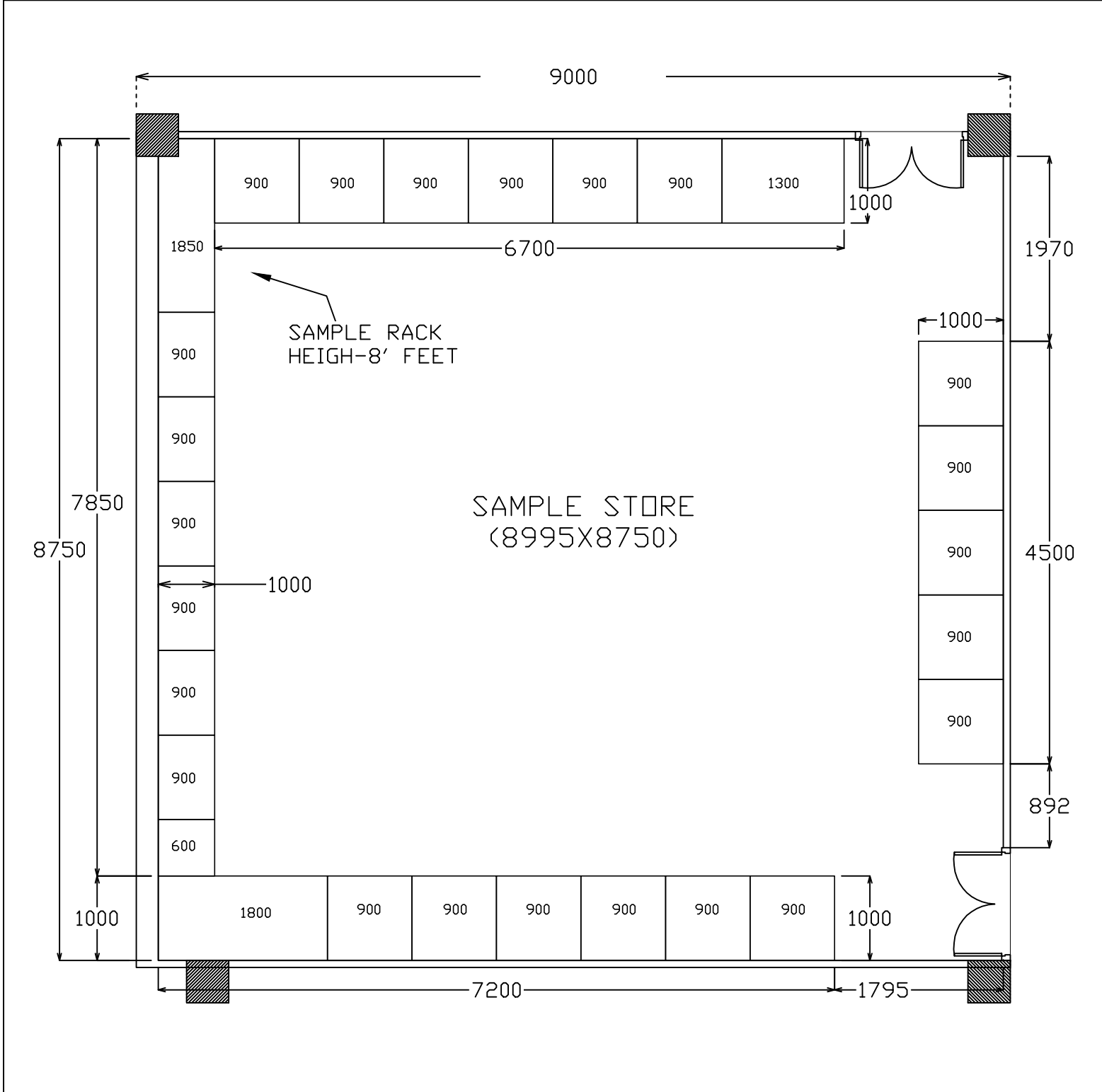

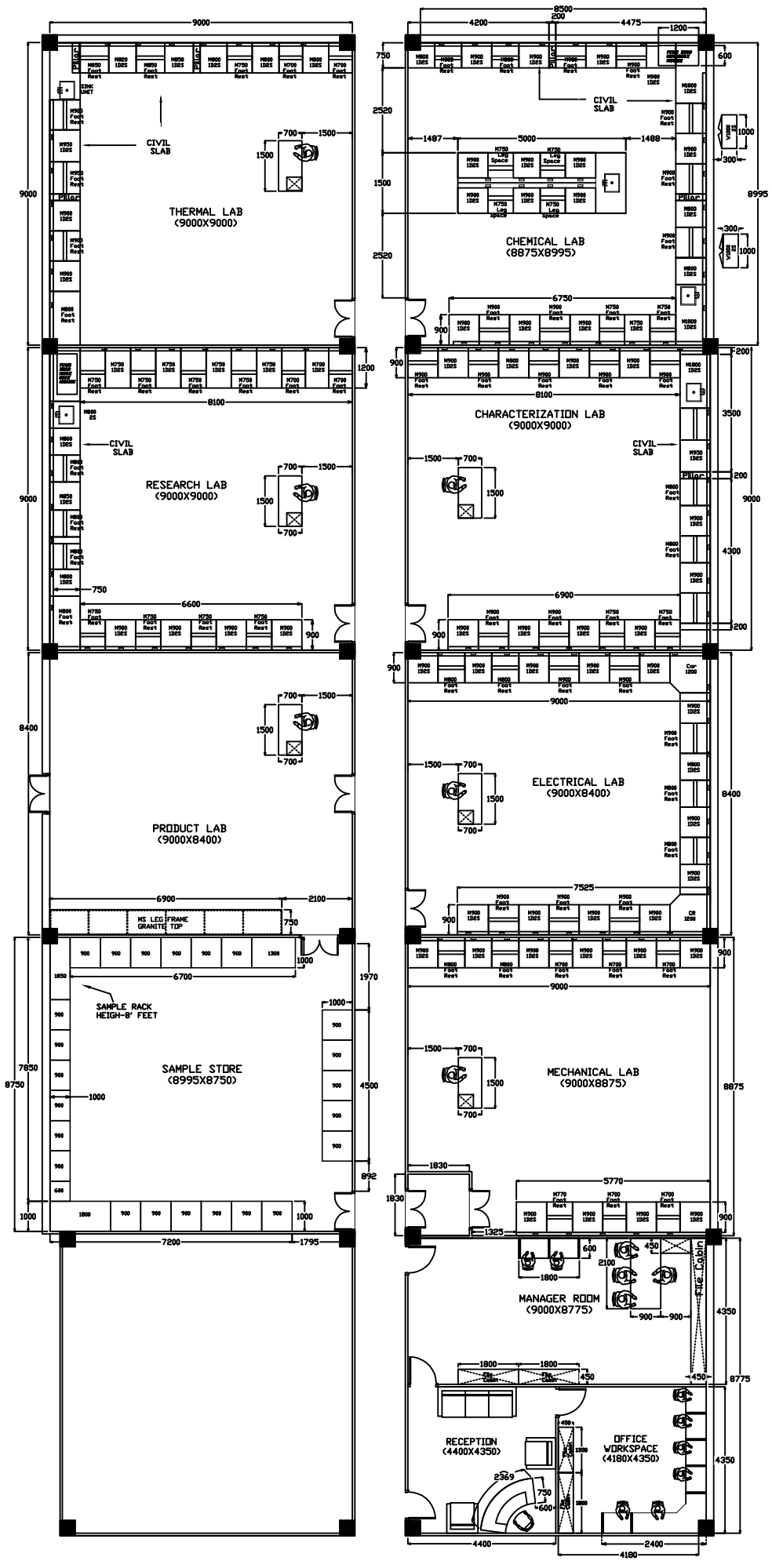

TESTING

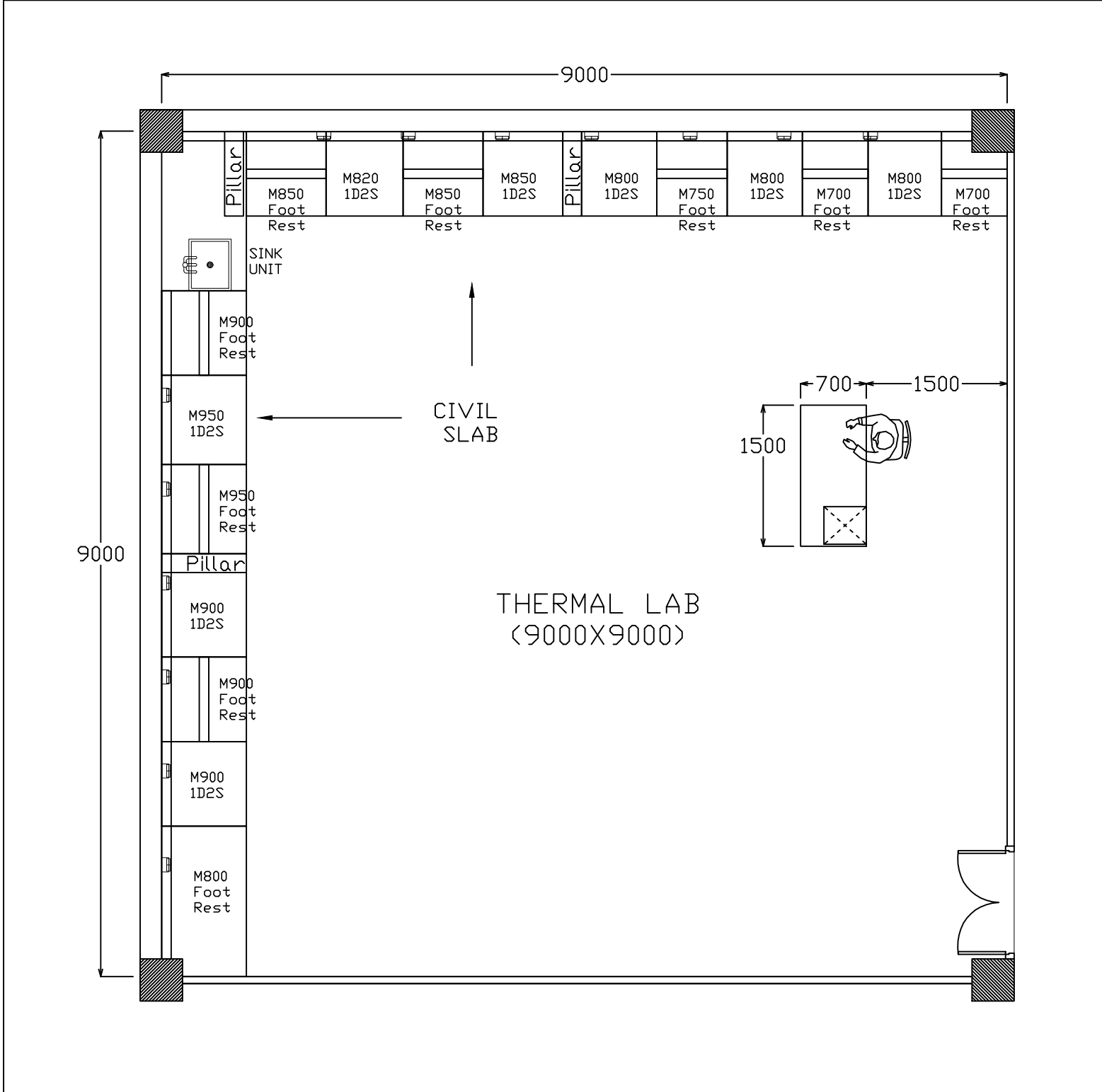

CIPET:CSTS, GWALIOR  
ANNEXURE-IV

Sr. No.	Particulars	Qty	Rate Per Unit	Amount
1	<b><u>MECHANICAL LAB</u></b> <b>Supply &amp; Fixing Side Wall Table</b> Size: 9000 x 900 X 900 (L x W x H) - 1 No. Size: 5770 X 900 X 900 (L x W x H) - 1 No. (Drawing & Specification enclosed)	1 1	No. No.	
2	<b><u>ELECTRICAL LAB</u></b> <b>Supply &amp; Fixing U Shape work Table</b> Size: 6325+1200+6000+1200 +7800 x 900 x 900 (L x W x H) (Drawing & Specification enclosed)	1	No.	
3	<b><u>CHARACTERIZATION LAB</u></b> a) <b>Supply &amp; Fixing Side Wall Table</b> Size: 8100 X 900 X 900 (L x W x H) Size: 6900 X 900 X 900 (L x W x H)	1 1	No. No.	
	b) <b>Cabinets under civil platform with doors &amp; Locks</b> Size : 9000 X 750 X 900 (L x W x H) (Drawing & Specification enclosed)	1	No.	
4	<b><u>CHEMICAL LAB</u></b> a) <b>Supply &amp; Fixing Side Wall Table</b> Size: 6750 X 900 X 900 (L x W x H) (Drawing & Specification enclosed)	1	No.	
	b) <b>Cabinets under civil platform with doors &amp; Locks</b> Size: 17100 X 750 X 900 (L x W x H) (Drawing & Specification enclosed)	1	No.	
	c) <b>Supply &amp; fixing Centre Table with reagent rack</b> Size: 5000 x 1800 x 900 (L x W x H) (Drawing & Specification enclosed)	1	No.	
	d) <b>Wall cupboards</b> Size : 1000 x 300 x 600 mm LWH (Drawing & Specification enclosed)			
5	<b><u>THERMAL LAB</u></b> Cabinets under civil platform with doors & Locks Size : 17250 X 750 X 900 (L x W x H) (Drawing & Specification enclosed)	1	No.	
6	<b><u>RESEARCH LAB</u></b> a) <b>Cabinates under civil platform with doors &amp; Locks</b> Size : 9000 X 750 X 900 (L x W x H)	1	No.	
	b) <b><u>Supply &amp; Fixing side wall table</u></b> Size : 8100 x 1200 x 900 (L x W x H) Size : 6600 x 900 x 900 (L x W x H) (Drawing & Specification enclosed)	1 1	No. No.	

7	<b><u>PRODUCT LAB</u></b>			
a)	<b>Work Table of MS Legs frame and granite Top</b> Size : 6900 X 750 X 900 (L x W x H) (Drawing & Specification enclosed)	1	No.	
8	<b><u>SAMPLE STORE</u></b> M.S. Structure with Racks and 4 Equal Space by M.S. Sheet Size : 4500 x 1000 X 2400 (L x W x H) - 1 No. Size : 6200 X 1000 X 2400 (L x W x H) - 1 No. Size : 6300 X 1000 X 2400 (L x W x H) - 1 No. Size : 7750 X 1000 X 2400 (L x W x H) - No. (Drawing & Specification enclosed)	1 1 1 1	No. No. No. No.	
9	<b><u>OFFICE / MANAGER / RECEPTION</u></b>			
a)	<b>Reception</b> Curved Shape Reception Table Size : 2369 X 750 X 750+450 (L x W x H) (Drawing & Specification enclosed)	1	No.	
b)	<b>Office</b> L Shape Computer Table / Aluminium powder coated modular work station Size : 3150 X 600 X 750+450 (L x W x H) Size : 1800 X 600 X 750+450 (L x W x H) Size : 1200+1200 X 600 X 750+450 (L x W x H) Size : 1200 X 750 X 600+450 (L x W x H) (Drawing & Specification enclosed)	1 1 1 1	No. No. No. No.	
c)	<b>Manager / HOD</b> Office Table Size : 2100 X 900 X 750 (L x W x H) (Drawing & Specification enclosed)	1	No.	
d)	<b>File Cupboard</b> Size : 4350 X 450 X 2100 (L x W x H) Size : 3600 X 450 X 2100 (L x W x H) (Drawing & Specification enclosed)	1 1	No. No.	
e)	<b>Technical Table</b> Size : 1500 X 700 X 750 (L x W x H) (Drawing & Specification enclosed)	1	No.	
	<b>Total</b>			-

**NOTE : ABOVE RATES ARE INCLUDING GST, TRANSPORTATION AND INSTALLATION.**

**Terms & Conditions:**

- 1 **Payment:**
- 2 Delivery: within 4 - 6 weeks
- 3 Offer validity :
- 4 Warranty :