

Central Institute of Petrochemicals Engineering & Technology (CIPET)

(Dept. of Chemicals & Petrochemicals Ministry of Chemical & Fertilizers, Gov. Of India)

Plot No J-3/2, Chikhalthana, MIDC Industrial Area,

Aurangabad – 431006

Tel: 0240-2478302/03/04/05/10/17

E-Mail- Aurangabad@cipet.gov.in

Web Site www.cipet.gov.in



E-TENDER DOCUMENT FOR

SUPPLY & INSTALLATION OF MACHINERY/EQUIPMENTS

E-TENDER NO.CIPET/AWB/PUR/MACH/2021-22/10

LAST DATE FOR SUBMISSION OF TENDER: 25/03/2022,03.00 p.m

SECTION I. INSTRUCTIONS TO BIDDERS

A. Introduction

1. CIPET is a premier national institution under the aegis of the Dept.of Chemicals & Petrochemicals Ministry of Chemicals & Fertilizers Govt. of India. & Fertilizers, Govt. of India fully devoted to Skill Development, Technology Support Services, Academic and Research (STAR). CIPET operates on hub & spokes model with 24 locations - 7 High Learning Centre's (IPT), 24 Other Learning Centre's (CSTS), 2 sub centers , 3 R & D Wings, spread across the country catering to the needs of Polymer and allied industries. 5 more centers' are in the process of establishment.

B. THE BIDDING DOCUMENTS

2. Content of Bidding Documents

- 2.1 The Online Bidding Documents include;
 - (a) Instruction to Bidders;
 - (b) Terms and Conditions of Contract;
 - (c) Schedule of Requirements;
 - (d) Technical Specifications;
 - (e) Manufacturer's Authorization Form;
 - (f) Bid Form and Price Schedules;
 - (g) Contract Form;
 - (h) Performance Security Form;
 - (i) Deviation Statement;

- 2.2 The Bidder is expected to examine all instructions, forms, terms and specifications in the Bidding Documents. Failure to furnish all information required by the Bidding Documents or submission of a bid not substantially responsive to the Bidding Documents in every respect will be at the Bidder's risk and may result in rejection of the bid.

3. Amendment of Bidding Documents

- 3.1 At any time prior to the deadline for submission of bids, the Purchaser may, for any reason, whether at their own initiative or in response to a clarification requested by a prospective bidder, modify the Bidding Documents by amendment.
- 3.2 In order to afford prospective Bidders reasonable time in which to take the amendment into account in preparing their bid, the Purchaser may, at their discretion, extend the deadline for the submission of bids.

C. PREPARATION OF BIDS

4 Documents Comprising the Bid

4.1 The bid prepared by the Bidder shall comprise of the following components:

- (a) A Bid Form and Price Schedule completed in accordance with Clauses 5 and 6;
- (b) Documentary evidence establishing in accordance with Clause 7 that the Bidder is eligible to bid and is qualified to perform the contract if its bid is accepted
- (c) Documentary evidence establishing in accordance with Clause 8 that the goods (machinery/equipment/software) and ancillary services are conforming to the Bidding Documents;

5. Bid Form

5.1 The Bidder shall complete the Bid Form and the appropriate Price Schedule furnished in the Bidding Documents, indicating for the goods to be supplied, a brief description of the Goods, their country of origin, quantity and prices.

An EMD Amount to be paid online as per following details

Sl No	Name of the Equipment/Machinery	Qty	Approximate Cost (Amt In Lakhs)	EMD Amount (Rs.)
1.	Testing Equipments for Toy Testing as per IS 9873 (Part 1) (2019)	01	23.00	46000.00

Tender Fees Rs.2950/- and EMD Amount as per table given above (online transfer on CIPET Aurangabad State Bank of India A/c No.11162576624 and IFSC Code: SBIN0003449

5.2 Bidder Registered Under Micro & Small Enterprise (MSE's) as defined as MSE Procurement policy issued by department of MSME or register with central purchase Organization will be considered for relaxation of EMD if proper certificate is enclosed.

6. Bid Prices

- 6.1 The Bidder shall indicate on the price schedule attached to these documents, the unit prices and total Bid Prices of the goods, proposed to supply under the Contract.
- 6.2 Fixed Price: Prices quoted by the Bidders shall be fixed during the Bidder's Performance of the Contract and not subject to variation on any account. A bid submitted with an adjustable price quotation will be treated as non-responsive and rejected.
- 6.3 Agents and service facilities in India:
If a foreign bidder has engaged an Indian agent, it will be required to give the following details in the offer:
- (i) The name and address of the local agent;
 - (ii) What service the agent renders; and
 - (iii) The amount of remuneration for the agent included in the offer

7. Documents establishing Bidder's Eligibility and Qualifications

- 7.1 Pursuant to Clause 4, the Bidder shall furnish, as part of its bid, documents establishing the bidder's eligibility to bid and its qualifications to perform the Contract if its bid is accepted.
- 7.2 The documentary evidence of the Bidder's qualifications to perform the Contract if its bid is accepted, shall establish to the Purchaser's satisfaction:
- (a) That, in the case of a Bidder offering to supply goods under the contract which the Bidder did not manufacture or otherwise produce, the Bidder has been duly authorized (as per authorization form in Section V) by the goods manufacturer or producer to supply the goods in India.
 - (b) That, in the case of a Bidder not doing business within India, the Bidder is or will be (if successfully represented by an agent in India) equipped and able to carry out the Supplier's maintenance, repair and spare-parts stocking obligations prescribed by the Conditions of the Contract and / or Technical Specifications
 - (c) That the Bidder has the financial, technical, and production capability necessary to perform the Contract and meets the criteria outlined in the qualification criteria specified in Section IX (Bidders should furnish information on their past performance at least 05 Years and as per proforma in Section-IX A) .

8. Documents Establishing Goods' Eligibility and Conformity to Bidding Documents

- 8.1 The Bidder shall furnish, as part of its bid, documents establishing the eligibility and conformity to the Bidding Documents of all goods and services which the bidder proposes to supply under the Contract.
- 8.2 The documentary evidence of the goods and services eligibility shall consists of a statement in the Price Schedule on the country of origin of the goods and services which shall be confirmed by a certificate of origin at the time of shipment.
- 8.3 The documentary evidence of the goods and services conformity to the Bidding Documents may be in the form of literature, drawings and data, and shall Furnish:
- (a) a detailed description of the goods essential technical and performance Characteristics;
 - (b) A list giving full particulars, including available sources and current prices, of all Spare parts, special tools, etc., may be quoted as an additional cost, which may be considered if required; and
 - (c) a clause-by-clause commentary on the Purchaser's Technical Specifications demonstrating the goods and services substantial responsiveness to those specifications or a statement of deviations and exceptions to the provisions of the Technical Specifications (As per deviation statement in section IX Annexure)
- 8.4 For purposes of the commentary, the Bidder shall note that standards for workmanship, material and equipment, and references to brand names or catalogue numbers designated by the Purchaser in its Technical Specifications are intended to be descriptive only and not restrictive. The Bidder may substitute alternative standards, brand names and/or catalogue numbers in its bid, provided that it demonstrates to the Purchaser's satisfaction that the substitutes are substantially equivalent or superior to those designated in the Technical Specifications.

9. Period of Validity of Bids

- 9.1 Bids shall remain valid for 180 days after the date of bid opening prescribed by the Purchaser. A bid valid for a shorter period may be rejected by the Purchaser as non-responsive.
- 9.2 In exceptional circumstances, the Purchaser may solicit the Bidder's consent to an extension of the period of validity. The request and the responses thereto shall be made in writing (or by cable or fax or e.mail). A Bidder may refuse the request without forfeiting its bid security. A Bidder granting the request is not be required or permitted to modify its bid.

10. Submission of Online Bids

10.1 The detailed technical specification of the equipment is enclosed as Section IV of Online Bid document, Offer should be of two parts Viz., **TECHNICAL BID** and **COMMERCIAL BID** The content of the both bids should be as under;

- 1) **Online TECHNICAL BID should include the following:-**
 - a) Detailed specification of the base equipment along with the specification of
 - i. Accessories, which are included in the Base unit.
 - ii. Deviation Statement
 - iii. Product Literature
 - iv. Proforma for Performance Statement for last 5 years (Annexure IX A)
 - v. Qualification Criteria (Annexure IX)
 - vi. List of spare parts included (without quoting the price) (the acceptance and rejection of spare parts will be at sole discretion of CIPET)
 - vii. List of optional accessories with their technical specification. (Without quoting the price)
 - viii. Manufacturer's Authorization Form
 - ix. Bid Form
 - x. Any other information which the bidder would like to state about the technically of the equipment.
- (b). **Online COMMERCIAL BID should include the following:-**
 - i. Statement showing the price of the each items of spare parts which is mentioned in the Technical Bid (the acceptance and rejection of spare parts as per Requirement will be at sole discretion of CIPET)
 - ii. Conditional bids will not be accepted. The condition laid down by CIPET is final and binding on all bidders.
 - iii. The quote should be in Indian Currency (INR).
 - iv. CIPET reserves the right to accept or reject any or all tenders either in part or in Full without assigning any reasons thereof.
The bids, which are not containing the statements, mentioned in 10.1 (a) & (b) are liable to be rejected.
- 10.2 The proforma of Annexures (Sections) in the Bidding document wherever necessary, should be typed on the bidder's letter head and upload the same.
- 10.3 Price Schedule should be submitted in the prescribed format given under price schedule of the Bidding Document.
- 10.4 The Deviation Statement enclosed should be duly filled in and submitted along with Bidding Document. If the bidder is offering more than one options/models a separate. Deviation statement for each of such quotes should be submitted along with the offer.
- 10.5 Quotes received without price schedule, and deviation statement as per our prescribed format, will summarily be rejected.
- 10.6 Relaxation of Norms for Startup and Micro & Small Enterprises in Public Procurement on Prior Experience - Prior Turnover Criteria and EMD.

11. Deadline for online Submission of Bids

The Purchaser may, at its discretion, extend this deadline for submission of bids by amending the Bid Documents in accordance with Clause 3, in which case all rights and obligations of the Purchaser and Bidders previously subject to the deadline will thereafter be subject to the dead-line as extended.

12. Evaluation and Comparison of Bids

12.1 The Purchaser will evaluate and compare the bids previously determined to be substantially responsive.

12.2 The availability in India of spare parts and after-sales services for the equipment offered (imported goods) - in the bid; (the inclusion of cost of spare parts for comparison as per requirement will be at sole discretion of CIPET) CIPET reserves right to accept any bid and to reject any bid or all bids.

13. Contacting the Purchaser

No Bidder shall contact/correspond/ communicate the Purchaser on any matter relating to the bid at any time.

D. AWARD OF CONTRACT

14. Post qualification

14.1 The Purchaser will determine to its satisfaction whether the Bidder selected as having submitted the lowest evaluated responsive bid is qualified to satisfactorily perform the Contract.

14.2 The determination will take into account the Bidder's financial, technical and production capabilities. It will be based upon an examination of the documentary evidence of the Bidder's qualifications submitted by the Bidder, pursuant to Clause 8, as well as such other information as the Purchaser deems necessary and appropriate.

14.3 An Affirmative determination will be a prerequisite for award of the Contract to the Bidder. A negative determination will result in rejection of the Bidder's bid,

15. Purchaser's right to vary Quantities at Time of Award

The Purchaser reserves the right at the time of award of Contract to increase or decrease of the quantity of goods and services specified in the Schedule of Requirements without any change in price or other terms and conditions.

16. Purchaser's Right to accept any Bid and to reject any or All Bids

The Purchaser reserves the right to accept or reject any bid, and to annul the bidding process and reject all bids at any time prior to award of Contract, without thereby incurring any liability to the affected Bidder or Bidders or any obligation to inform the affected Bidders or Bidders of the grounds for the purchaser's action.

17. Performance Security

Within 21 days of the receipt of Notification of award of Contract from the Purchaser, the successful Bidder shall furnish the performance security in accordance with the Conditions of Contract, in the Performance Security Form provided In the Bidding Documents .

SECTION - II. TERMS AND CONDITIONS OF CONTRACT

1. The following are the Terms and Conditions of Contract.

2. Definitions

- (a) The purchaser is : CIPET, Chikhalthana MIDC Area, Aurangabad- 32, Maharashtra, India,
- (b) The Supplier is

3. Performance Security

3.1 Within 21 days after the Supplier's receipt of Purchase Contract, the Supplier shall furnish performance security to the Purchaser for an amount of 5% of the contract value valid up to 60 days after the date of Completion of performance Obligations including warranty obligations.

3.2 The Performance Security shall be denominated in the currency of the Contract or in a freely convertible currency acceptable to the Purchaser, and shall be in one of the following forms:

- (a) A Bank guarantee or irrevocable Letter of Credit, issued by a nationalized bank located in India and in the form provided in the Bidding Documents or another form acceptable to the purchaser; or
- (b) Demand Draft in favour of CIPET, payable at Aurangabad. (INDIA).

3.3 The performance security will be discharged by the Purchaser and returned to the Supplier not later than 60 days following the date of completion of the Supplier's performance obligations, including any warranty obligations, under the Contract.

4. Delivery and Documents

(a) For Imported Goods

- (i) Original and three copies of Supplier's invoice showing Goods description, Quantity, unit price, total amount.
- (ii) Original and three copies of the negotiable clean, on -board bill of lading marked freight prepaid and three copies of non-negotiable bill of lading.
- (iii) Five Copies of packing list identifying contents of each package.
- (iv) Insurance Certificate.
- (v) Manufacturer's /Supplier's guaranty certificate.
- (vi) Inspection certificate, issued by the nominated inspection agency and the supplier factory inspection report; and
- (vii) Certificate of Origin.

(b) For Domestic Goods:

Original and Three copies of:

- (viii) Copies of the Supplier invoice showing Goods description, quantity, unit price, total amount.
- (ix) Railway receipt / Acknowledgement of receipt of goods from the consignee(s);
- (x) Manufacturer's / Supplier's guarantee Certificate;
- (iv) Inspection Certificate issued by the nominated inspection agency and the Supplier's factory inspection report.
- (xi) Certificate of origin and
- (xii) Document evidence for sales tax/octroi etc., wherever applicable, bearing seal of Office of issue indicating payments made extra.

The above documents shall be received by the Purchaser before arrival of the goods (except where the goods have been delivered directly to the consignee with all documents) and if not received, the supplier will be responsible for any consequent expenses.

5. Incidental Services

The following services covered shall be furnished and the cost shall be included in the Contract price;

- (i) Complete erection of all equipments
- (ii) Commissioning of all equipments. This includes trial run and proving test.
- (iii) Furnishing of detailed operations and maintenance manual for each
Appropriate unit of supplied Goods:

6. Spare Parts

Supplier shall carry sufficient inventories to assure ex-stock supply of consumables, spares such as gaskets, plugs, washers, belts etc., Other spare parts and components shall be supplied as promptly as possible but in any case within one month of Placement of order.

7. Warranty/Guarantee

7.1 The Supplier warrants that the Goods supplied under this Contract are new, unused, of the most recent or current models and incorporate all recent improvements in design and materials unless provided otherwise in the Contract. The Supplier further warrants that the Goods supplied under this Contract shall have no defect arising from design, materials or workmanship (except insofar as the design or material is required by the Purchaser's Specifications) or from any act or omission of the supplier, that may develop under normal use of the supplied Goods in conditions obtaining in the country of final destination.

7.2 This warranty/guarantee shall remain valid for 24 months after the Goods or any portion thereof as the case may be, have been delivered and commissioned at the final destination indicated in the Contract.

7.3 The Purchaser shall promptly notify the Supplier, in writing, of any claims arising under this warranty.

7.4 Upon receipt of such notice, the Supplier shall, with all reasonable speed, repair or replace the defective Goods or parts thereof, without cost to the Purchaser.

7.5 If the Supplier, having been notified, fails to remedy the defect(s) within a reasonable period, the Purchaser may proceed to take such remedial action as may be necessary, at the Supplier's risk and expense and without prejudice to any other rights which the Purchaser may have against the Supplier under the Contract.

7.6 The Supplier must provide the following warranties:

- (a) The equipment proposed is Complete in every way
- (b) The hardware/software specification, Capabilities and performance characteristics are as stated in the bidder's proposal and accompanying documentation.
- (c) The supplier will offer to the Purchaser all technological updates, cost reductions and facilities, which are offered to other clients, in India, during the Contract tenure.

If the supplier is acting directly for the manufacturer of the Goods and Services, the Manufacturer must honor these guarantee.

The MAINTENANCE SERVICE shall be as follows.

- (a) Free maintenance services shall be provided by the Supplier during the period of warranty.
- (b) The maximum response time for maintenance complaint from any of the destination specified in the Schedule of requirements (i.e. time required for supplier's maintenance engineer to report at the installation after a request call/email is made or letter is written) shall not exceed 24 hours.

9. Payment

9.1 Payment of contract shall be made in the INR specified in the bid in the following manner:

- (i) **On Receipt of Goods:** 75% of the Contract Price for supply of Goods received shall be paid of receipt of goods at the destination and submission of claim supported by the Acceptance Certificate issued by the Purchaser's representative.
- (ii) Erection of Goods and Final Acceptance after commissioning at site: 15% of the Contract price for supply and commissioning and other incidental services, on completion of erection and commissioning of Goods/ Equipments at site and other service certificate issued by the Purchaser's representative.
- (iii) Final installation of 10% after three months of performance evaluation (starts from installation date.)

10. Prices

Prices payable to the supplier as stated in the contract shall be firm and not subject to any adjustment.

11. Sub-contracts

The Supplier shall notify the Purchaser in writing of all subcontracts awarded under the Contract if not already specified in his bid. Such notification, in his original bid or later, shall not relieve the Supplier from any liability or obligation under the Contract.

Sub contracts shall be only be bought out items and sub assemblies.

12. Resolution of Disputes

The dispute resolution mechanism to be applied shall be as follows:

- a) In the case of a dispute or difference arising between the purchaser and Domestic Supplier relating to any matter arising out or connected with this agreement, such dispute or different shall be referred to International Centre for Alternative Dispute Resolution, New Delhi.
- b) In the case of a dispute between the purchaser and a foreign supplier, the dispute shall be settled by arbitration in accordance with provision of sub clause (a) above. But if this be not acceptable to the supplier, then the dispute shall be settled in accordance with the provisions of the unitary arbitration rules.
- c) The Indian Arbitration Act 1940, the rules there under and any statutory modification or re-enactments thereof, shall apply to the arbitration proceedings.

The venue of arbitration shall be the place from where the contrast is issued.

13. Notices

For the purpose of all notices, the following shall be the address of the Purchaser and Supplier.

Purchaser: Central Institute of Petrochemicals Engineering &Technology (CIPET),
Plot No J-, Chikhalthana MIDC Area, Aurangabad - 431006. (INDIA)

Supplier: (To be filled at the time of Contract Signature).....

14. Supplier Integrity

- 14.1 The Supplier is responsible for and obliged to conduct all contracted activities in accordance with the Contract using state-of- the art methods and economic principles and exercising all means available to achieve the performance, specified in the Contract.

15. Supplier Obligation

- 15.1 The Supplier is obliged to work closely with the Purchaser staff, act within its own authority and abide, by directives issued by the Purchaser on implementation activities.
- 15.2 The Supplier will abide by the job safety measures prevalent in India and will free the Purchaser from all demands or responsibilities arising from accidents or loss of life the cause of which is the supplier's negligence. The supplier will pay all indemnities arising from such incidents and will not hold the purchaser responsible or obligated.
- 15.3 The Supplier is responsible for managing the activities of its personnel or sub-contacted personnel and will hold itself responsible for any misdemeanors.
- 15.4 The Supplier will treat as confidential all data and information about the purchaser, obtained in the execution of his responsibilities, in strict confidence and will not reveal such information to any other party without the prior written approval of the purchaser.

16. Technical Documentation

- 16.1 The technical documentation involving detailed instruction for operation and Maintenance is to be delivered with every unit of equipment supplied. The language of the documentation should be English.

17. Liquidated Damages:-

If the Supplier fails to deliver any or all of the goods within the time period(s) specified in the Contract ,the Purchaser shall, without prejudice to its other remedies under the contract, deduct from the Contract Price, as liquidated damages, a sum equivalent to 0.5 percent of the delivered price of the delayed goods or unperformed services for each week of delay until actual delivery or performance, up to a maximum deduction of Max of 10% of the delayed goods or services Contract price. Once the maximum is reached, the purchaser may consider termination of the contract.

18. Evaluation and comparison of substantially Responsive Bids

Only those bids which are qualified for Technical Part will be considered for examination in the financial part.

If there is tie in the rates offered the bid scrutiny committee decides the awarding the contract depending upon their

1. Last three years Annual Turnover
2. Nos of years of experience in related service in Govt/Pvt Organization
3. The decision of Principal Director & Head shall be final in this regard.

19. Summary of Rejection of Bids

Any one or more than one of the following actions/commissions are likely to cause rejection of Bid:

- 1.Any Bid received after due date and time
- 2.Any bid not accompanied by required bid security of received for shorter validity period or insufficient amount of security
- 3.Any Bid received offline
- 4.Any conditional Bid
- 5.Any bid in which rates have not been quoted in accordance with specified formats/details as specified in tender document.
- 6.Any bid received not signed by duly authorized signatory at all appropriate places.

20. All Legal matter will be under Aurangabad Judiciary only.

21.For all bidders Rule 144(Xi) in the General Financial Rules (GFRs) 2017 Order (Public Procurement No.3) dated 24th July 2020 (Restriction from Land Border sharing countries) by Ministry of Finance, Department of Expenditure will be applicable.

SECTION III.SCHEDULE OF REQUIREMENTS

S. No	Name of Equipment	Qty	Delivery Period
1	Supply & installation of machinery/ equipments- Specification sheet Enclosed Separately	1 No Each	90 days

**** Any extension of delivery period to be communicated in writing with Appropriate valid reasons.**

SECTION IV. TECHNICAL SPECIFICATIONS

Equipments offered are required for Training purposes and should from the manufacturer's own standard of production, in supply and conforming as near as possible.

Sl. No	Name of Equip ment	Quantity
1	Supply & installation of machinery/ equipments Specification sheet Enclosed Separately (Annexure A)	1 No each

Annexure A

Equipment Specification for Toy Test Lab
As per IS 9873 Part I (2019)

Sr. No.	Name of the Equipment	Cl. No. (IS 9873 Part I)(2019)	Equipment Specification
1	Accessibility of a Part or Component A & B	5.7 (DRAWING ATTACHED)	Articulated accessibility probe,
2	Sharp-edge test Equipment (with 1 inch PTFE Tape)	5.8	Sharp-edge test as per Figure 31, Steel Mandrel, Device for rotating the mandrel and applying a force to it, Pressure sensitive polytetrafluoroethylene (PTFE) tape
3	Sharp Point Tester	5.9	Point tester,
4	Test for Fixed Loop & Nooses Head Probe	5.11	Suitable apparatus capable of applying and measuring tensile forces up to (25 ± 2) N, instruments to measure length and cross sectional area of cords e.g. an optical projector, head probe (see Figure 35), hook test fixture (Figure 36), mass of $(1 \pm 0,1)$ kg, conditioning chamber to maintain samples at a temperature of (25 ± 3) °C and at a relative humidity of 50 % to 65%
5	Hook Test Fixture for Cords & Loops	5.11	Suitable apparatus capable of applying and measuring tensile forces up to (25 ± 2) N, instruments to measure length and cross sectional area of cords e.g. an optical projector, head probe (see Figure 35), hook test fixture (Figure 36), mass of $(1 \pm 0,1)$ kg, conditioning chamber to maintain samples at a temperature of (25 ± 3) °C and at a relative humidity of 50 % to 65%
6	Stability & Over Load Test	5.12	smooth surfaces inclined $10+0.5^\circ/-0.0^\circ$ and $15+0.5^\circ/-0.0^\circ$, $10 \pm 1^\circ$ to the horizontal plane, Loads for stability test $(25 \pm 0,2, 50 \pm 0,5)$ kg), Loads for overload test $(35 \pm 0,3, 80 \pm 1,0, 140 \pm 2,0)$
7	Durability for Toy Chest Lids Automatic	5.13	Suitable apparatus capable of applying and measuring tensile forces up to $(45 \pm 1,3)$ N in an outward direction to the inside of the closure perpendicular to the plane of the closure Durability test apparatus to subject the lid to 7 000 opening-and-closing cycles, where one cycle consists of raising the lid from its fully closed to its fully open position and returning it to fully closed. The time to complete one cycle shall be approximately 15 s. The 7 000 cycles shall be completed within a time period of 72 h
8	Kinetic Energy of Projectiles	5.15	Timing device for determining the velocity, to give a calculated kinetic energy to an accuracy of 0,005 J.
9	Free-wheeling facility and brake performance test	5.16	Apparatus for Stability and overload tests, surface covered with aluminium oxide

			paper P60, Apparatus to Pull the toy at a constant speed of $(2 \pm 0,2)$ m/s and apply and measure forces of (50 ± 2) N to the pedal in the operating direction producing the effect of the brake, mass of $(50 \pm 0,5)$ kg
10	Determination of Speed of electrically driven ride on toys.	5.17	mass of $(25 \pm 0,2)$ kg, horizontal surface, Apparatus to check if velocity exceeds 8 km/h.
11	Lickage of liquid filled toys (Needle)	5.19	Conditioning chamber to condition toy at a temperature of (37 ± 1) °C, Apparatus to apply a force of 5 N to the external surface of the toy through a steel needle with a diameter of $(1 \pm 0,1)$ mm and with a tip radius of $(0,5 \pm 0,05)$ mm
12	Durability of Mouth Actuated Toys Automatic	5.20	Durability test apparatus comprising piston pump capable of discharging and receiving more than 300 cm ³ of air in less than 3 s to the mouthpiece of the mouth-actuated toy with a relief valve so arranged that the pump will not generate a positive or negative pressure of more than 13,8 kPa.
13	Tip Over test Apparatus	5.24.3	Tip-over test for large and bulky toys: Apparatus to Gradually apply a force, which is not to exceed 120 N, in a horizontal direction and 1 500 mm above the horizontal surface or at the top edge of the toy for toys less than 1 500 mm in height. A non-resilient step with a height of (25 ± 2) mm shall be positioned such that it prevents sliding or rolling of the toy during the test.
14	Torque test (Torque gauge)	5.24.5	Torque test: torque gauge or torque wrench to apply torque of $(0,45 \pm 0,02)$ N·m
15	Flexure test	5.24.8 (DRAWING ATTACHED)	Flexure test: Apparatus as per 5.24.8
16	Determination of sound pressure levels	5.25	Environment that meets the qualification requirements of either ISO 11201 or ISO 11202, Equipment for Noise measurement in dB including instrumentation system, including the microphone and cable as per class 1 instrument as specified in IEC 61672-1, standard test table as described in ISO 11202 (wooden top with a thickness of 4 cm or larger and leg construction providing a stable test surface), hypothetical box-shaped measurement surface (see Figure 43), reflecting plane (for example, concrete, tile or another hard surface) and a test rig for Pull or push toys, test rig for Cap firing toys
17	Static strength for toy scooters	5.26	Test masses for toy scooters of $(50 \pm 0,5)$ kg, (100 ± 1) kg of dimensions as per Figure 47
18	Dynamic strength for toy scooters	5.27	Load as specified in Figure 48, equipped with two articulated arms and a removable cushion with straps, platform

19	Brake performance for toy scooters	5.28	250 mm high platform (with stabilizers) with a total mass of $(4,8 \pm 0,2)$ kg as shown in Figure 49, mass of $(50 \pm 0,5)$ kg, $(25 \pm 0,2)$ kg, Setup to apply and measure force applied up to 20 kg/30 N.
20	Strength of toy scooter steering tubes	5.29	horizontal plane equipped to secure the toy scooter, mass of $(25 \pm 0,2)$ kg, $(50 \pm 0,5)$ kg, (100 ± 1) kg
21	Resistance to separation of handlebar	5.30	Setup to apply and measure force applied up to 90 N
22	Tension test for magnets	5.31	Tension test apparatus with Nickel disc with a minimum nickel content of 99 %, a diameter of $(30 \pm 0,5)$ mm and thickness of $(10 \pm 0,5)$ mm.
23	Magnetic flux index	5.32	Magnetic flux index test apparatus with Direct current field Gauss meter, with a resolution of 5 G, capable of determining the field to an accuracy of 1,5 % or better. The meter shall have an axial type probe with an active area diameter of $(0,76 \pm 0,13)$ mm and a distance between the active area and probe tip of $(0,38 \pm 0,13)$ mm, Caliper, or similar device, with an accuracy of 0,1 mm.
24	Determination of projectile range	5.35 (DRAWING ATTACHED)	Apparatus to Discharge the projectile using a discharge angle that will maximize the distance travelled (typically this is 45°). At the point of discharge, the projectile shall be disengaged from the discharge mechanism and in free flight
25	Tension and Compression test	5.24.6	Tension and Compression test: Tension and Compression Test Apparatus with loading device equipped with a self-indicating gauge or other appropriate means to measure force applied to accuracy of 1 N.

- Standard: Must comply IS 9873 Part I (2019)
- Material :MS Powder Coated and/or suitable material to comply the standard
- Dimension of the equipment As per respective clauses of IS 9873 Part I (2019)
- Calibration: NABL calibration certificate required (as per the requirement of respective clauses of IS 9873 Part I (2019))
- Reference Material: NIST Traceable (as per the requirement of respective clauses of IS 9873 Part I) (2019)
- Accessories/Apparatus: Must Provided as per requirement of respective clause/equipment
- Accuracy: As per respective clauses of IS 9873 Part I (2019)
- Warranty: 2 Years

5.7 Articulated Accessibility Probe

Clause	5.7
Specification	As per IS 9873 (Pt-1)

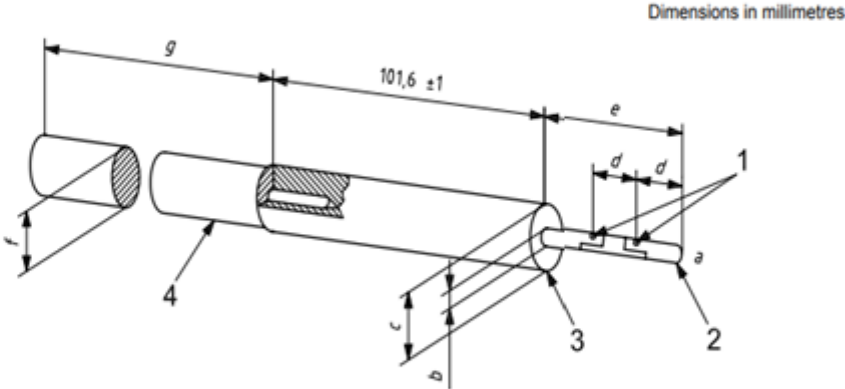

- Key**
- 1 pivot points
 - 2 spherical radius (a)
 - 3 collar
 - 4 extension

Fig. A schematic of prospective Apparatus

5.24 Reasonably forceable abuse

Clause	4.2
Specification	
Name of Equipment	Flexure test apparatus

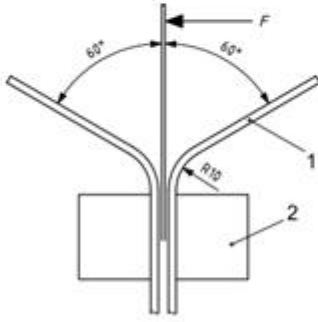

Fig. A schematic of prospective Apparatus

5.35 Determination of projectile range

Clause	4.18
Specification	Apparatus to Discharge the projectile using a discharge angle that will maximize the distance travelled (typically this is 45°). At the point of discharge, the projectile shall be disengaged from the discharge mechanism and in free flight and as per IS 9873 (Pt-1)
Name of Equipment	Projectile range

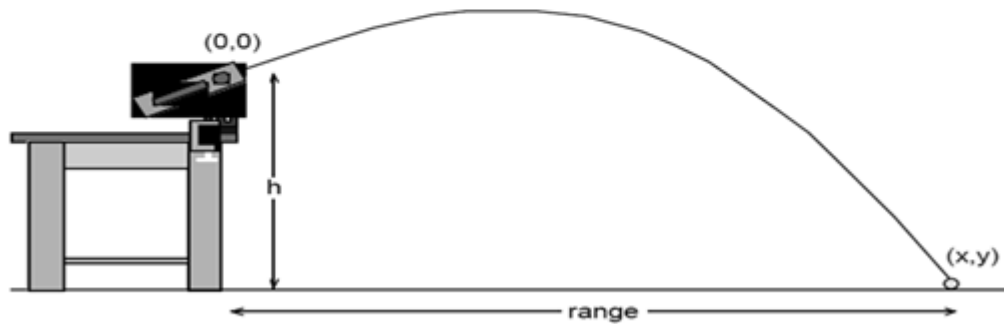

Fig. A schematic of prospective Apparatus

SECTION V MANUFACTURER'S AUTHORIZATION FORM

No.....dated.....

To
M/s. Central Institute of Petrochemicals Engineering &
Technology (CIPET)
Plot No J-3/2, Chikhalthana MIDC Area,
Aurangabad - 431006,
Maharashtra, India.

Dear Sir

Ref: Bid Reference

We who are established and
reputable manufacturers ofhaving factories at
.....and.....do hereby authorize
M/s.....
M/s.....
M/s.....etc
(Name and address of Agents) to bid and conclude the contract with you against the
above Bid are authorized to bid and conclude the contract in regard to this business
against this specific Bid.

We hereby extend our full guarantee and warranty as per clause 8 of the Terms and
Conditions of Contract for the goods offered for supply against this invitation for bid by the
above firms.

Yours Faithfully,

(Name)
for and on behalf of M/s.....
(Name of Manufactures)

Note: This letter of authority should be on the letterhead of the manufacturing
concern and should be signed by a person competent and having the power of
attorney to bind the manufacturer.

SECTION VI. BID FORM AND PRICE SCHEDULES

Date:.....

Contract No:.....

To :

M/s. Central Institute of Petrochemicals Engineering & Technology
Plot No J-3/2, Chikhalthana MIDC Area, Aurangabad - 431006
Tamil Nadu, INDIA.

Gentlemen:

Having examined the Bidding Documents including Addenda Nos.(insert Numbers), the receipt of which is hereby duly acknowledged, we, the undersigned, offer to supply and deliver (Description of Goods and Services) in conformity with the said Bidding Documents for the sum of (Total Bid Amount in Words and Figures) or such other sums as may be ascertained in accordance with the schedule of prices attached herewith and made part of this bid.

I/We have examined the details of the equipments to be supplied and have carefully noted the conditions of contract and the specification /drawings with all stipulations of which I/we agreed to comply.

We undertake, if our bid is accepted, to commence delivery within (Number) days and to complete delivery of all the items and perform incidental services as specified in the Contract within (Number) days calculated from the date of receipt of your Notification of Award/Letter of Credit.

If our bid is accepted, we will obtain the guarantee of a bank in a sum not exceeding.....% of the Contract Price for the due performance of the Contract.

We agree to abide by this bid for a period of (Numbers) days from the date fixed for bid opening under Clause 9 of the Instruction to Bidders and shall remain binding upon us and may be accepted at any time before the expiration of that period.

Until a formal Contract is prepared and executed, this bid, together with your written acceptance thereof and you notification of award, shall constitute a binding contract between us.

We understand that you are not bound to accept the lowest or any bid you may receive.

Dated this.....day of.....20.....

Signature:

(in the capacity of):.....

Duly Authorized to sign bid for and on behalf of

SECTION VII. CONTRACT FORM

THIS AGREEMENT made theday of,20.....
Between **Central Institute of Petrochemicals Engineering & Technology, Plot No J-3/2, Chikhalthana MIDC Area, Aurangabad - 431006. of India** (hereinafter “the Purchaser”) of one part and (Name of Supplier) of (City and Country of Supplier) hereinafter “ the Supplier” of the other part:

WHEREAS the Purchaser is desirous that certain equipments and ancillary services should be provided by the Supplier, Viz., (Brief Description of Goods and Services) and has accepted a bid by the Supplier for the supply and services of those Goods and Services in the sum of (Contract Price in Words and Figures) (hereinafter “ the Contract Price”).

NOW THIS AGREEMENT WITNESSETH AS FOLLOWS:

1. In this Agreement, words and expressions shall have the same meanings as are respectively assigned to them in the conditions of Contract hereinafter referred to.
2. The following documents shall be deemed to form and be read and construed as part of this Agreement, viz.:
 - (a) The bid Form and Price schedule submitted by the Bidder;
 - (b) The Schedule of Requirements;
 - (c) The Technical Specifications;
 - (d) Terms and Conditions of Contract; and
 - (e) The Purchaser’s Notification of Award.
3. In consideration of the payments to be made by the Purchaser to the Supplier as hereinafter mentioned, the Supplier hereby covenants with the Purchaser to provide the Goods and Services and to remedy defects there in conformity in all respects with the provisions of the contract.
4. The Purchaser hereby covenants to pay the Supplier in consideration of the provision of the Goods and Services and the remedying of defects therein, the Contract Price or such other sum as may become payable under the provisions of the Contract at the times and in the manner prescribed by the Contract.

PRICE SCHEDULE

BASIC EQUIPMENT/MACHINERY

Value in Rs.

Sl. No	Brief Description of Goods & Services - Name of Equipment/Machinery	Quantity (Nos)	Unit Price	Value
1	Submission Financial Bid Online As per format	1 Each Machine		
2	Add: Taxes & Duties (GST, if applicable etc.)			
Total (1+2)				

Total Value : in INR

SIGNATURE OF BIDDER

Date :

Name :

Place:

Business Address:

Note: Price Schedule should be typed on the letter head of bidder duly signed and stamped and for Technical specification, it has to be given in separate price schedule.

SECTION VIII. PERFORMANCE SECURITY FORM

To:

Central Institute of Petrochemicals Engineering & Technology, Plot No J-3/2, Chikhalthana MIDC Area, Aurangabad - 431006. India.

WHEREAS..... (Name of Supplier)

Hereinafter called "the Supplier" has undertaken, in pursuance of Notification of Contract No..... dated, 20..... to supply (Description of Goods and Services) hereinafter called "the Contract".

AND WHEREAS it has stipulated by you with a Bank Guarantee by a recognized bank for the sum specified therein as security for compliance with the Supplier's performance obligations in accordance with the Contract. **AND WHEREAS** we have agreed to give the Supplier a Guarantee:

THEREFORE WE hereby affirm that we are Guarantors and responsible to you, on behalf of the Supplier, up to a total of (Amount of the Guarantee in Words and Figures) and we undertake to pay you, upon your first written demand declaring the Supplier to be in default under the Contract and without cavil or argument, any sum or sums within the limit of (Amount of Guarantee) as aforesaid, without your needing to prove or to show grounds or reasons for your demand or the sum specified therein.

This guarantee is valid until theday of.....20.....

Signature and Seal of Guarantors

.....
.....

Date

Address :.....

SECTION IX

(Referred to in clause 7.2 C of Instruction to bidders)

QUALIFICATION CRITERIA

- (a) The bidder should be a manufacturer/authorized distributor/agent of a manufacturer, who must have designed, manufactured, tested and supplied the equipment(s) of same/similar to the type specified in the Schedule of requirements.
- (b) The bidder should furnish the information on the past three year's supplies of same/similar machine in the proforma given under Section IX-A.
- (c) Bidders shall invariably furnish at least two documentary evidences (Client's Certificates) in support of the satisfactory operation of the equipment for the same/similar machine supplied by him in the last five years.
- (d) The bidder should furnish the scope of Supply in as Separate Sheet clearly mentioning the Model number,name of equipment and technical details.
- (e) An undertaking from the Original Manufacturer of the supply of goods/equipments (OEM) stating that they would facilitate the bidder on a regular basis with technology/product update should be submitted.

SECTION IX - A

(Please see clause 7.2 (c) of instruction to bidders)

PROFORMA FOR PERFORMANCE STATEMENT

(for Similar/Same Goods/Equipment for a period of last three years)

Bid No.....Date of opening.....Time.....Hours

Name of the Firm.....

Order placed By (Full address of Purchaser)	Order No and date	Description and quantity of ordered equipment	Value of order (Optional)	Date of completion of delivery As per Contract Actual		Remarks indicating reasons for late delivery, if any	Has the equipment been satisfactorily functioning?
1	2	3	4	5	6	7	8
<hr/>							

Signature and seal of the Bidder

(Please submit the copy of the installation / commissioning report from minimum 2 buyers

SECTION X

PROFORMA FOR DEVIATION STATEMENT

Please see Clause 8.3 (C) of Instructions to Bidders

Bid Ref No.

Date of Opening

Time :

Name of the Firm

Name of the Equipement quoted

Model No.:

Purchaser's Specification	Bidders Specification	Deviation, if any	Justification	Remarks

Note: Separate Deviation statements should be submitted along with the bid for all models / alternative quotes.

Note

CIPET reserves the right to accept or reject any or all tenders either in part or in full without assigning any reasons thereof.